



| REVISIONS | | | | |
|-----------|--------------------|---------|-----|-----|
| REV | DESCRIPTION | DATE | ENG | MFG |
| A | Production Release | 8/31/21 | MA | |



| | | | |
|---|----------------|-----------|--|
| <small>UNLESS OTHERWISE SPECIFIED DIMENSIONS ARE IN INCHES TOLERANCES ARE DECIMALS FRACTIONS .X ± 0.30 1/16 .XX ± 0.010 ANGLES .XXX ± 0.005 °</small> | APPROVALS | DATE | FCI WATERMAKERS Watermakers TEL (801)906-8840 <small>THE DIFFERENCE IS CLEAR</small> WWW.FCIWATERMAKERS.COM |
| | PREPARED BY | 8/31/2021 | |
| | CHECKED BY | | |
| | APPROVED BY | | |
| <small>THIS DRAWING CONTAINS PROPRIETARY INFORMATION OF FILTRATION CONCEPTS INC. IT SHALL NOT BE RELEASED, USED, DUPLICATED OR DISCLOSED IN WHOLE OR IN PART FOR MANUFACTURE OR PROCUREMENT WITHOUT THE EXPLICIT INTENT AND WRITTEN PERMISSION OF FCI WHICH RETAINS ALL DESIGN AND PATENT RIGHTS.</small> | | | TITLE MaxQ+ Framed Series Dimensions |
| SIZE | DRAWING NUMBER | REV | |
| A | | A | |
| DO NOT SCALE | | | SHEET 1 OF 6 |

4

3

2

1

B

B

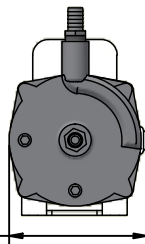
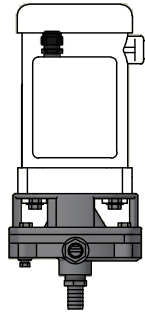

7.2 in
182.0 mm

6 in
15.9 mm

R.2 in
R4.8 mm

4.0 in
101.6 mm

4.0 in
101.6 mm

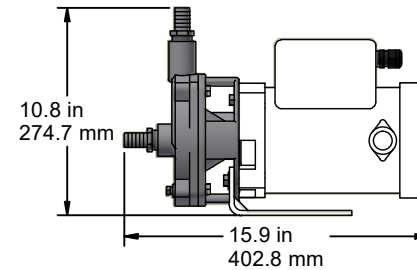

- 3** LOW PRESSURE PUMP FOR MAXQ+
- 2** DRY WEIGHT APPROX. 40.5 LBS / 18.4 KG
- 1** DIMENSIONS & WEIGHTS SUBJECT TO CHANGE WITHOUT NOTICE

| | | | | |
|---|----------------|----------|--------------|--|
| <small>UNLESS OTHERWISE SPECIFIED DIMENSIONS ARE IN INCHES. TOLERANCES ARE DECIMALS FRACTIONS .X ± .030 1/16 .XX ± .010 ANGLES .XXX ± .005 °</small> | APPROVALS | | DATE |  FCI WATERMAKERS TEL (801)906-8840 <small>THE DIFFERENCE IS CLEAR WWW.FCIWATERMAKERS.COM</small> |
| | PREPARED BY | Mark | 8/31/2021 | |
| | CHECKED BY | SM | | |
| | APPROVED BY | | | |
| <small>THIS DRAWING CONTAINS PROPRIETARY INFORMATION OF FILTRATION CONCEPTS INC. IT SHALL NOT BE RELEASED, USED, DUPLICATED OR DISCLOSED IN WHOLE OR IN PART FOR MANUFACTURE OR PROCUREMENT WITHOUT THE EXPLICIT INTENT AND WRITTEN PERMISSION OF FCI WHICH RETAINS ALL DESIGN AND PATENT RIGHTS.</small> | | | | TITLE Assy, LP Pump, SS, 1/2 HP, 1PH |
| SIZE | DRAWING NUMBER | REV | | |
| A | 40-2379 | B | DO NOT SCALE | SHEET 2 OF 6 |

4

3

2

1

A

A

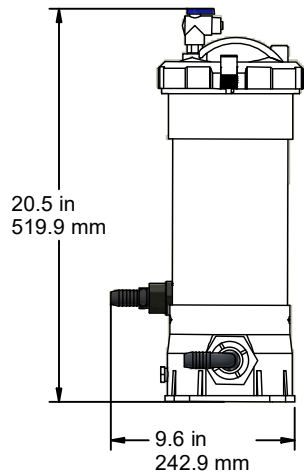
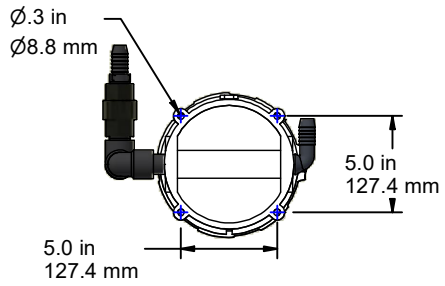
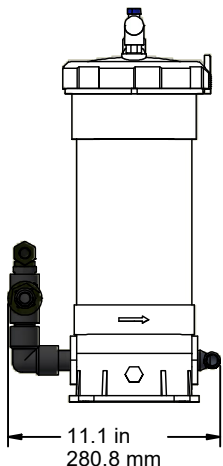
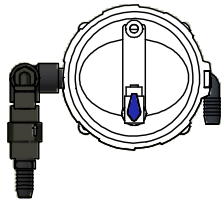

- 3** PRE-FILTER FOR MAXQ+
- 2** DRY WEIGHT APPROX. 7 LBS / 3.2 KG
- 1** DIMENSIONS & WEIGHTS SUBJECT TO CHANGE WITHOUT NOTICE

| APPROVALS | | DATE |
|-------------|-----|-----------|
| PREPARED BY | CAD | 8/31/2021 |
| CHECKED BY | SM | |
| APPROVED BY | | |

FCI WATERMAKERS
Watermakers TEL (801)906-8840
 THE DIFFERENCE IS CLEAR WWW.FCIWATERMAKERS.COM

TITLE: **Assy, Pre-Filter, 5 Micron, Aquamiser+/MaxQ+/Atlas+**

SIZE: **A** DRAWING NUMBER: **93-0001** REV: **A**

DO NOT SCALE SHEET 3 OF 6

UNLESS OTHERWISE SPECIFIED DIMENSIONS ARE IN INCHES. TOLERANCES ARE DECIMALS FRACTIONS
 .X: ± 0.030 1/16
 .XX: ± 0.010 ANGLES
 .XXX: ± 0.005 °

THIS DRAWING CONTAINS PROPRIETARY INFORMATION OF FILTRATION CONCEPTS INC. IT SHALL NOT BE RELEASED, USED, DUPLICATED OR DISCLOSED IN WHOLE OR IN PART FOR MANUFACTURE OR PROCUREMENT WITHOUT THE EXPLICIT INTENT AND WRITTEN PERMISSION OF FCI WHICH RETAINS ALL DESIGN AND PATENT RIGHTS.

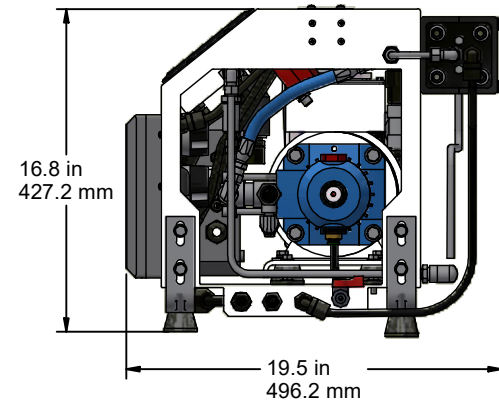
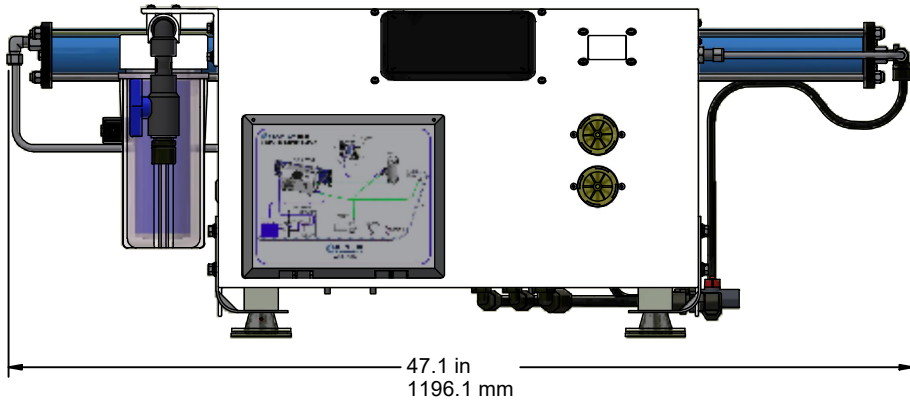
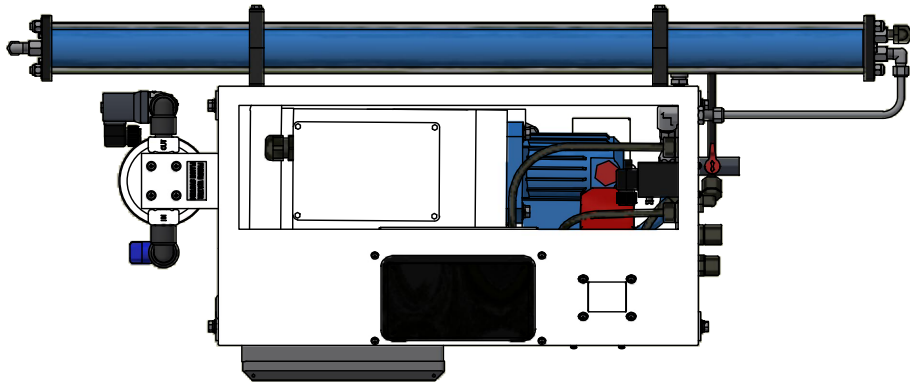

2 DRY WEIGHT APPROX. 195 LBS / 88.5 KG

1 DIMENSIONS & WEIGHTS SUBJECT TO CHANGE WITHOUT NOTICE

| | | | | |
|---|----------------|--------------|--|-----------|
| <small>UNLESS OTHERWISE SPECIFIED DIMENSIONS ARE IN INCHES. TOLERANCES ARE: DECIMALS FRACTIONS .X: ± .030 1/16 .XX: ± .010 ANGLES .XXX: ± .005 °</small> | APPROVALS | DATE |  FCI WATERMAKERS TEL (801)906-8840 <small>THE DIFFERENCE IS CLEAR</small> WWW.FCIWATERMAKERS.COM | |
| | PREPARED BY | CAD | | 8/31/2021 |
| | CHECKED BY | SM | | |
| | APPROVED BY | | | |
| <small>THIS DRAWING CONTAINS PROPRIETARY INFORMATION OF FILTRATION CONCEPTS INC. IT SHALL NOT BE RELEASED, USED, DUPLICATED OR DISCLOSED IN WHOLE OR IN PART FOR MANUFACTURE OR PROCUREMENT WITHOUT THE EXPLICIT INTENT AND WRITTEN PERMISSION OF FCI WHICH RETAINS ALL DESIGN AND PATENT RIGHTS.</small> | | | TITLE MaxQ+APC 700 GPD | |
| SIZE | DRAWING NUMBER | REV | | |
| A | MQ726+APC | C | | |
| DO NOT SCALE | | SHEET 4 OF 6 | | |

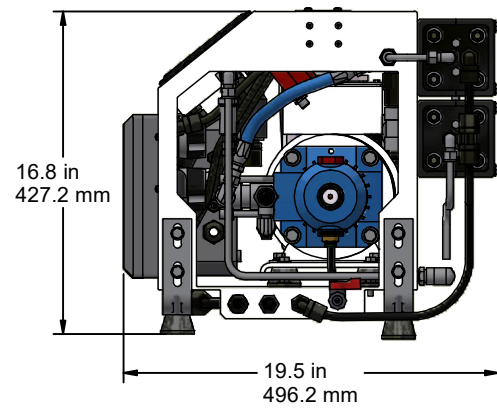
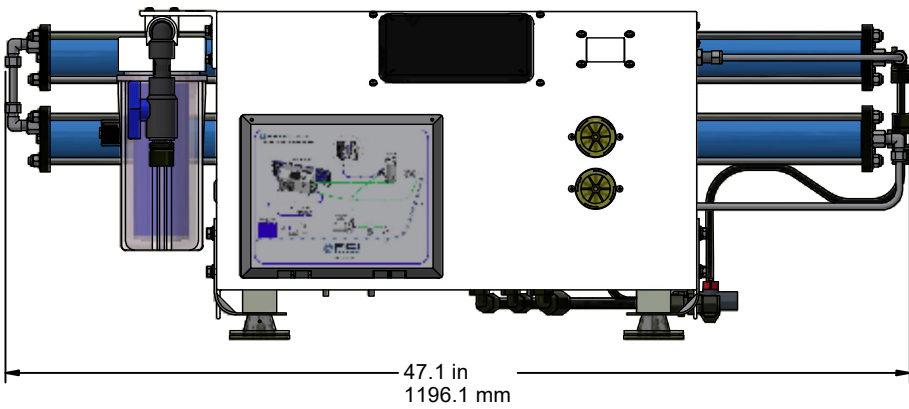
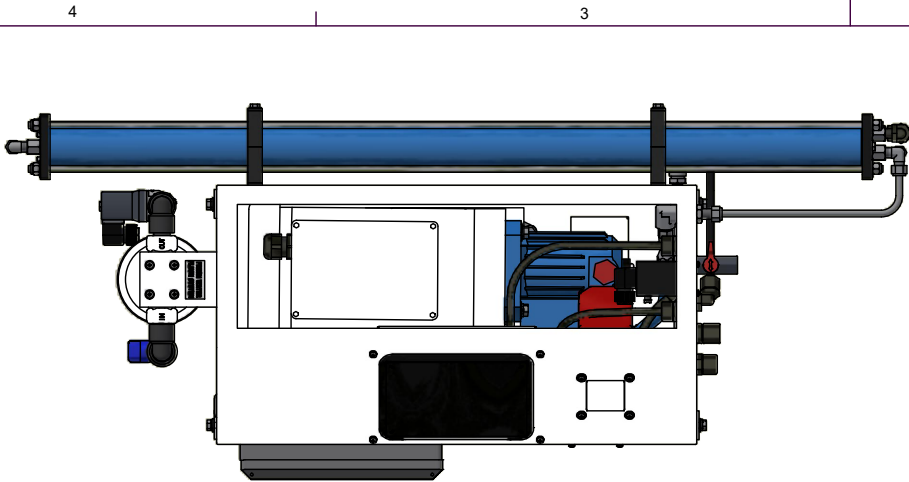

2 DRY WEIGHT APPROX. 205 LBS / 93.0 KG

1 DIMENSIONS & WEIGHTS SUBJECT TO CHANGE WITHOUT NOTICE

| | | | | |
|---|----------------|--------------|--|-----------|
| <small>UNLESS OTHERWISE SPECIFIED DIMENSIONS ARE IN INCHES TOLERANCES ARE DECIMALS FRACTIONS .X ± .030 1/16 .XX ± .010 ANGLES .XXX ± .005 °</small> | APPROVALS | DATE |  FCI WATERMAKERS TEL (801)906-8840 <small>THE DIFFERENCE IS CLEAR</small> WWW.FCIWATERMAKERS.COM | |
| | PREPARED BY | CAD | | 8/31/2021 |
| | CHECKED BY | SM | | |
| | APPROVED BY | | | |
| <small>THIS DRAWING CONTAINS PROPRIETARY INFORMATION OF FILTRATION CONCEPTS INC. IT SHALL NOT BE RELEASED, USED, DUPLICATED OR DISCLOSED IN WHOLE OR IN PART FOR MANUFACTURE OR PROCUREMENT WITHOUT THE EXPLICIT INTENT AND WRITTEN PERMISSION OF FCI WHICH RETAINS ALL DESIGN AND PATENT RIGHTS.</small> | | | TITLE MaxQ+APC 1275 GPD | |
| SIZE | DRAWING NUMBER | REV | | |
| A | MQ1226+APC | C | | |
| DO NOT SCALE | | SHEET 5 OF 6 | | |

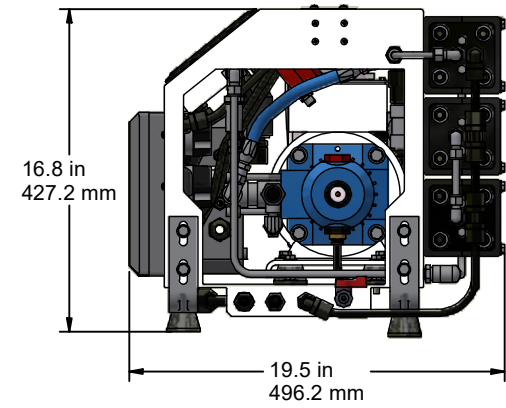
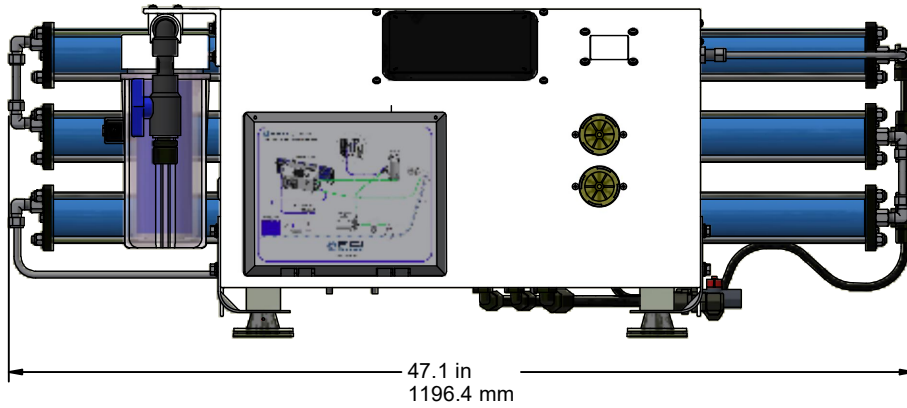
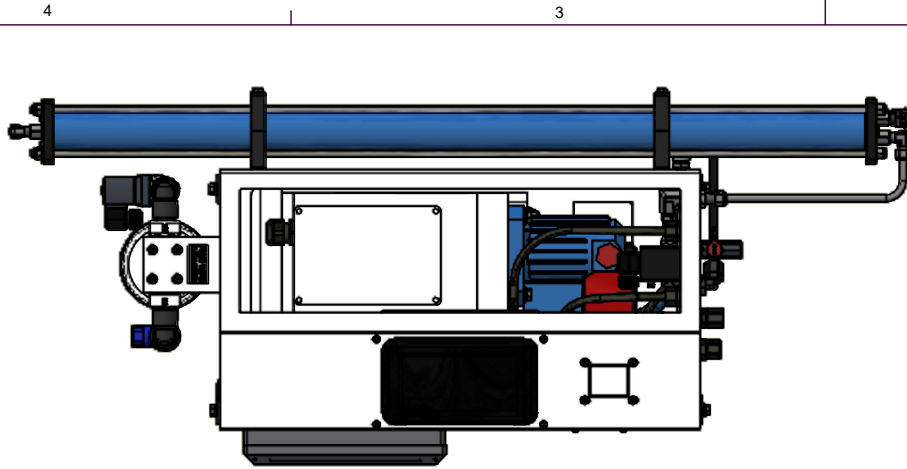

2 DRY WEIGHT APPROX. 215 LBS / 97.5 KG

1 DIMENSIONS & WEIGHTS SUBJECT TO CHANGE WITHOUT NOTICE

| | | | | |
|---|----------------|--------------|---|-----------|
| <small>UNLESS OTHERWISE SPECIFIED DIMENSIONS ARE IN INCHES. TOLERANCES ARE: DECIMALS FRACTIONS .X ± .030 1/16 .XX ± .010 ANGLES .XXX ± .005 °</small> | APPROVALS | DATE |  FCI WATERMAKERS TEL (801)906-8840 WWW.FCIWATERMAKERS.COM <small>THE DIFFERENCE IS CLEAR</small> | |
| | PREPARED BY | CAD | | 8/31/2021 |
| | CHECKED BY | SM | | |
| | APPROVED BY | | | |
| <small>THIS DRAWING CONTAINS PROPRIETARY INFORMATION OF FILTRATION CONCEPTS INC. IT SHALL NOT BE RELEASED, USED, DUPLICATED OR DISCLOSED IN WHOLE OR IN PART FOR MANUFACTURE OR PROCUREMENT WITHOUT THE EXPLICIT INTENT AND WRITTEN PERMISSION OF FCI WHICH RETAINS ALL DESIGN AND PATENT RIGHTS.</small> | | | TITLE MaxQ+APC 1850 GPD | |
| SIZE | DRAWING NUMBER | REV | | |
| A | MQ1826+APC | C | | |
| DO NOT SCALE | | SHEET 6 OF 6 | | |